

ProfiMaster, two exhaust arms

Art. No.: 60 650 DA 103



Technical Data

| Filter | |
|-----------------------------|---------------------------|
| Filter stages | 2 |
| Filter method | Storage Filter |
| Filter surface | 17 m ² |
| Type of filter | Filter cassette |
| Filter material | Non-woven fibre |
| Filter efficiency | > 99,5 % |
| Filter class | E12 |
| Additional filters | Pre-filter |
| Basic data | |
| Extraction capacity | 2 x 700 m ³ /h |
| Dimensions (w x t x h) | 797 x 828 x 977 mm |
| Weight | 113,8 kg |
| Motor power | 1,1 kW |
| Power supply | 3 x 400 V / 50 Hz |
| Rated current | 2,3 A |
| Control voltage | 24 V, DC |
| Noise level | 72 dB(A) |
| Additional information | |
| Fan type | Radial fan |
| Quantity of extraction arms | 2 |
| Exhaust arm type | rigid metal tube arm |
| Diameter extraction arm | 150 mm |
| Length of exhaust arm | 2 m |

Applications

- Low to medium levels of smoke and dust
- Occasional to frequent use
- For two work places

Benefits

- Safe operation by rotation field control
- Maintenance door allows easy filter change
- Exhaust arm requires less adjustment due to flow-optimised exhaust hood design
- Increased safety due to filter monitoring
- Space-saving solution due to two extraction arms
- Possibility of working in two alternating places due to dampers in the extraction hood

Properties

- Exhaust arm up to 4 m
- Rotating exhaust hood

Accessories

- Automatic start-stop

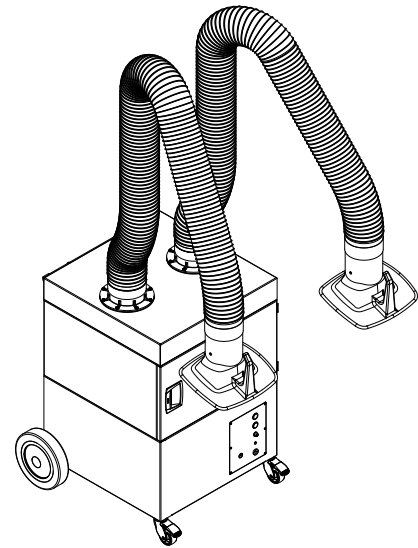
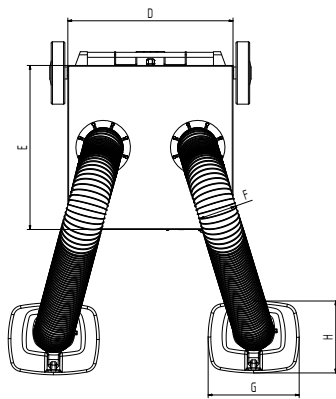
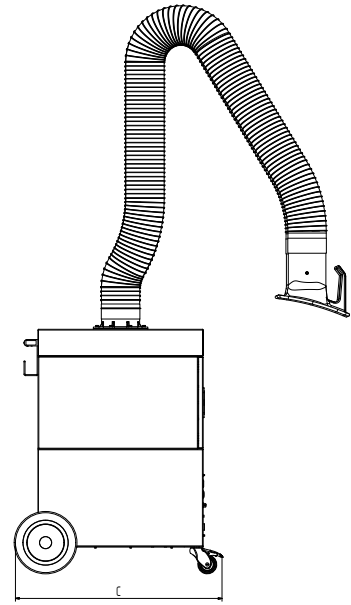
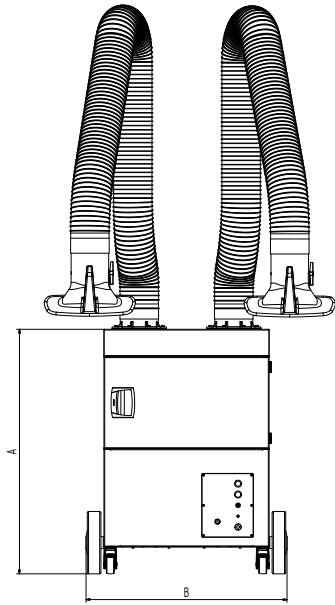

Technical Data

Dimensions

| | |
|---|--------|
| A | 977 mm |
| B | 797 mm |
| C | 828 mm |
| D | 655 mm |
| E | 655 mm |
| F | 150 mm |
| G | 360 mm |
| H | 295 mm |